



ALPINE SHIRE

## **Food Premises Planning Guide**

# **WITH INFORMATION ON PREPARING AND SUBMITTING PLANS AND SPECIFICATIONS**

**NOTE: Under the Victorian Food Act it is not a mandatory requirement to submit plans for approval prior to applying for registration of food premises.**

**JUNE 2013**

# CONTENTS

PLANNING/BUILDING APPLICATIONS .....	2
ESTABLISHING A NEW FOOD PREMISES .....	3
REGISTRATION PROCEDURES AND APPROVALS .....	3
FLOORS .....	4
WALLS .....	7
WINDOWS .....	7
CEILINGS.....	7
LIGHTING.....	8
VENTILATION AND EXHAUST EQUIPMENT .....	8
PLANS AND SPECIFICATIONS .....	9
EXHAUST HOODS .....	9
CANOPY TYPE HOODS.....	10
SIDE DRAFT HOODS .....	11
MAKE UP AIR .....	11
FILTRATION.....	11
EXHAUST OPENINGS IN HOOD .....	12
HOOD ENCLOSURES .....	12
DUCTS .....	12
NOISE EMISSION.....	14
SAFETY.....	14
FURNITURE AND EQUIPMENT .....	15
BENCHES AND SHELVES .....	15
COOL ROOMS AND FREEZERS .....	15
TYPICAL FOOD PREPARATION AREA.....	16
TYPICAL WASH UP AREA .....	17
SINK AREAS & WATER SUPPLY.....	18
WASTE WATER DISPOSAL.....	19
HAND WASH BASINS .....	19
STAFF PERSONAL EFFECTS AND CLOTHING .....	19
TOILET FACILITIES.....	20
FOOD STORAGE AND HANDLING.....	21
SELF SERVE .....	22
FLY AND VERMIN PROOFING .....	23
NAME ON FRONT OF FOOD PREMISE .....	23
STRUCTURAL MAINTENANCE AND CLEANLINESS .....	23
CHECKLIST .....	24
NOTES .....	25

## PLANNING/BUILDING APPLICATIONS

Appropriate plans may be submitted to the following Departments:

Type of Plans and Specifications	Where to Submit
Food Establishment	<ul style="list-style-type: none"> <li>▪ Alpine Shire Council Environmental Health Department Ph 03 5755 0555</li> </ul>
Water Supply Tank Water	<ul style="list-style-type: none"> <li>▪ North East Water Ph: 1300 361 622</li> <li>▪ Alpine Shire Environmental Health Department – Ph 03 5755 0555</li> </ul>
Sewage Disposal System And Grease Traps	<ul style="list-style-type: none"> <li>▪ North East Water Ph 1300 361 622</li> <li>▪ Alpine Shire Environmental Health Department (for non-sewered areas) Ph 03 5755 0555</li> </ul>
Plumbing	<ul style="list-style-type: none"> <li>▪ North East Water Ph 1300 361 622</li> <li>▪ Alpine Shire Environmental Health Department ph 03 5755 0555</li> </ul>
Toilet Requirement	<ul style="list-style-type: none"> <li>▪ Alpine Shire Building Department Ph 03 5755 0555 or Private Building Surveyor</li> </ul>
Building	<ul style="list-style-type: none"> <li>▪ Alpine Shire Building Department Ph 03 5755 0555 or Private Building Surveyor</li> </ul>
Zoning	<ul style="list-style-type: none"> <li>▪ Alpine Shire Town Planning Department Ph 03 5755 0555</li> </ul>
Licensed and BYO Premises (Liquor Act)	<ul style="list-style-type: none"> <li>▪ Consumer Affairs Ph: 1300 650 367</li> </ul>

**Note:** All plans must be compliant with state and local building and plumbing codes.

Specifications should describe all equipment, including manufacturer's name and model numbers when applicable.

## **ESTABLISHING A NEW FOOD PREMISES**

Should you decide to operate a food premises, whether it is existing or you plan to construct or alter a building, you need to be aware that there are certain regulations and council requirements to consider.

It is recommended that you seek advice from Council's Planning, Building and Environmental Health departments to ensure you become familiar with all the facts relating to your application.

## **REGISTRATION PROCEDURES AND APPROVALS**

Well thought out, detailed plans and specifications result in orderly, less expensive construction, and allows measures to be taken that will help protect customers' health. Food businesses are required under state legislation to use premises and equipment that comply with Standard 3.2.3, Food Premises and Equipment, of the Australian New Zealand Food Standards Code and AS4674 – 2004, Design, construction and fit out of food premises.

Prior to the Food Premises opening for trade with the public, application is to be made to Council for registration with a Food Safety Program as per the Food Act 1984 (as amended.) An application together with plans and specifications of any work to be done on the premises to have it comply with the Food Premises Code of Practice, may be submitted.

Consideration must be given to the following items before preparing a final detailed plan:

- Customer traffic
- Parking and/or unloading of goods
- Equipment arrangements
- Flexibility of operation
- Decor and appointments to promote easy cleaning
- Basics for estimating cost and ensuring sufficient funds are available
- Provision for future expansion
- Disposal, storage and loading of wastes
- It is advisable to consult with the Environmental Health Department (with a draft plan) prior to preparing final plans.

## FLOORS

Floors are to be finished with approved impervious material, graded and drained to sewer, with the impervious material extended up the walls (**coving**) to a height of not less than 75mm in such a manner that the angles between the walls and the floors and concavely rounded off. This coving is required to assist with cleaning as it ensures an uninterrupted surface between floor and wall. **Coving** shall be installed in accordance with **Diagram 1** or other method that achieves the same outcome.

Floors should be appropriate for the area, non absorbent and easily cleaned. See **Table 1** for information on surfaces. All floors should be laid according to the relevant standards so that there is no ponding of water and harbouring of pests

### Food preparation areas

- Floors in food preparation should be finished with one or a combination of the following:
- Sealed quarry tiles or ceramic tiles
- Stainless steel
- Laminated thermosetting plastic sheeting
- Polyvinyl sheeting with welded seams
- Epoxy resin
- Steel trowel case hardened concrete
- Similar impervious material

### Food storage areas

Storage areas for unpackaged food including temperature-controlled storage (coolrooms), shall have floors that comply with requirements for food preparation areas.

Storage areas for dry packaged goods and vegetables need to be finished with a non-absorbent surface.

## Diagram 1

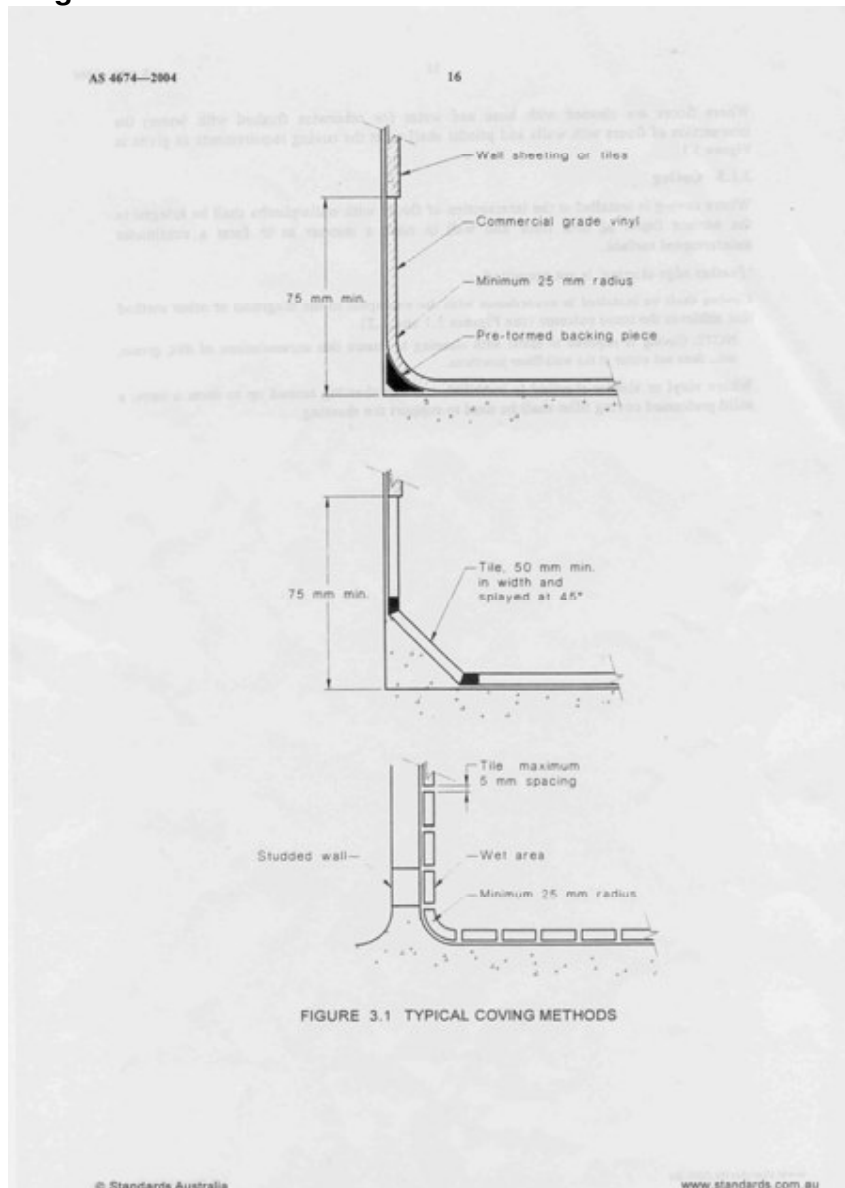

Coving at floor to wall joints makes cleaning easier and prevents accumulation of dirt or food that attracts insects and rodents.

**Floor Finishes for food premises Table 1**

Finish	Wet washed areas	Food Prep	Vegetable Prep	Servery	Store Room	Chillers/Freezers	Bin Store	Eating areas	Comments
Stainless Steel non slip profile	•	•	•	•	•	•	•	•	Welded joints
Ceramic tiles	•	•	•	•	•	•	•	•	Epoxy grout
Quarry tiles	•	•	•	•	•	•	•	•	Sealed
Steel trowel case hardened concrete			•		•	•	•	•	Smooth-sealed finish, no joints
Carpet/carpet tiles								•	
Wooden flooring								•	Sealed
Polyvinyl Sheet	•	•	•	•	•	•	•	•	Heat welded joints (not suitable adjacent hot fat appliances)
Laminated thermosetting plastic sheet	•	•	•	•	•	•	•	•	Heat welded joints (not suitable adjacent hot fat appliances)
Vinyl tiles					•			•	
Plastic Matting				•				•	Should be used for safety reasons only. It shall be easily cleaned and laid in sections that can be removable for cleaning
Cork tiles								•	Sealed
Epoxy resins	•	•	•	•	•	•	•	•	Complying with AS 3554

## WALLS

Walls are to be finished with a smooth and even surface by lining same with an approved material painted with washable light coloured gloss finish paint. Walls in direct contact with the preparation and working areas of the food premises shall be ceramic tiled, lined with stainless steel or another approval material, to a height of 1800 mm. The junction between adjacent wall finishes shall not form a ledge to ensure dust or grease cannot accumulate. The finishing of surfaces should be free of cracks, crevices, open spaces, screws and ledges.

Walls for food preparation areas need to be finished with one or a combination of the following:

- Glazed tiles
- Stainless steel or aluminium sheeting
- Laminated thermosetting plastic sheeting
- Polyvinyl sheeting with welded seems

Walls in storage areas need to meet the same specifications as for food preparation areas.

***Architraves, skirting boards, picture rails or any other projections on the walls of kitchens and food preparation areas are not permitted.***

## WINDOWS

Windows should be at least 300 mm above the top of any bench, table or equipment. If windowsills are provided they shall be splayed at least 45 degrees to the horizontal and finished with material matching the wall finish. All vertical or horizontal edges are to be rounded or bull nosed.

## CEILINGS

Ceilings are to be constructed of rigid, dust proof, smooth faced, non-absorbent material, painted with a washable gloss paint of a light colour. Such surface shall be of a finish free of open joints, cracks, crevices or openings. Intersections with walls shall be tight jointed, sealed and dustproof. Where a sealant is used, the sealant shall be of washable, impervious material.

Ceilings in food preparation and storage areas must be finished with impervious sealed material. Acoustic tile suspended ceilings over a food processing area is not permitted. Drop-in removable panel ceilings shall not be used in food preparation areas or over areas where open food is displayed or served.

Service pipes, conduits and electrical wiring shall be concealed in floors, walls or ceilings or fixed on brackets so as to provide at least 25mm clearance between the



pipe and adjacent vertical surface and 100mm between the pipe and adjacent horizontal surfaces. This is to allow cleaning and prevent the harbourage of pests.

## LIGHTING

Food premises must be provided with adequate natural and/or artificial lighting that complies with the Australian Standard AS 1680-1976. Light fittings where open food is handled should be designed to prevent the contamination of food should the globe break and should be free from any features that would harbour dirt or pests.

Only approved type light fittings which fit flush with the ceiling or fluorescent tubes protected by approved type covers may be fitted to ensure that not less than 300 Lux of light is available in all food preparation areas. Storage rooms should have a minimum of 200 Lux of light.

Diagrams of Standard Recessed and Fluroprism:



### **Standard Recessed**

Units providing a cover flange all around suitable for recessed use in fibrous plaster or other ceilings. Also available with anodised or enamelled aluminium hinged frame to order.

### **Fluroprism**

Economical fitting with spring fixed acrylic prismatic lens. Optically designed linear prisms control light in glare zones. Single unit has Fluroslim body. Twin unit has special full width body. Units have neat architectural lines and can be mounted in continuous runs by allowing 2 mm gaps for expansion.

***The Australian Standard for Interior Lighting and the Visual Environment (AS1680) - 1976 provides further guidance on interior lighting.***

## VENTILATION AND EXHAUST EQUIPMENT

All food premises require natural or mechanical ventilation in accordance with the Building Code of Australia and exhaust hoods that comply with Australian Standard AS 1668.2-1991 are to be installed over all cooking equipment.

All cooking and heating stoves and appliances in any food premises shall be ventilated in accordance with *Australian Standard 1668, The Use of Mechanical Ventilation and Air Conditioning in Buildings.*

No one shall install or permit to be installed a mechanical exhaust system in any food premises without the approval of the Council's Senior Environmental Health Officer.

## **PLANS AND SPECIFICATIONS**

Every application to install a mechanical exhaust system must include the following:

- (a) A plan of the premises to a metric scale of 1:100 (unless already submitted).
- (b) Two copies of fully dimensioned drawings showing end and front elevations of the proposed system to a metric scale of not less than 1:20. The drawings should include the following details:
  - The angle of the hood sides to the horizontal.
  - The height of the hood above the cooking appliances.
  - The number, size and type of cooking facilities to be ventilated (See “Safety”).
  - The number, size and type of filters (if required) and the angle of the filters to the horizontal.
  - A condensate gutter and drain plug.
  - All ducting, ie: size, length, bends, inspection openings, sump plugs and fire dampers.
  - Height of termination of duct above roof, position in relation to adjoining premises, and cowl type.
  - Exhaust fan type, capacity and mounting, and situation in the exhaust system.
  - Details of method of fixing canopy to walls, ceilings etc.
- (c) Details of make-up air to be provided.
- (d) Details of any other mechanical ventilation servicing the premises in which the proposed system is to be installed.

## **EXHAUST HOODS**

Exhaust hoods shall be:

- Of approved design and capable of being easily cleaned.
- Constructed of galvanised sheet metal or other approved impervious and fireproof material in a smooth, permanent and tradesman-like manner, with surfaces which are smooth and free from obstructions, (painting of interior surfaces is not permitted). All joints to be joined, seamed and/or riveted so as to be grease tight.
- Reinforced and supported where necessary to provide stability and freedom from vibration.

## CANOPY TYPE HOODS

Canopy type hoods shall be:

- Designed to extend not less than 150mm beyond the perimeter of all appliances to be ventilated.
- Provided with capture velocities in accordance with Appendix F of AS 1168.2 1991.
- Provided with a condensate gutter around the base of the hood, not less than 50 mm wide, and 25 mm in depth and drained to a suitable outlet. The section of gutter under any filters must be of sufficient width to collect any condensate drip from the lowest edge of the filters.
- Constructed so as not to provide any horizontal flat surface within the open section of the hood.
- Provided that special consideration may be given to a minimal area of horizontal flat surface within the hood where the hood design is restricted by the structural conditions of the room.
- Constructed to provide a vertical flat surface with abutting walls or partitions and to be securely fixed and sealed to such walls or partitions.
- Where lights are installed in the hood, they shall be recessed and enclosed in a vapour-proof housing with a shatter proof lens guard.
- Fire sprinklers may be placed in approved positions in canopies and ducts in accordance with AS 2118 - 1978.

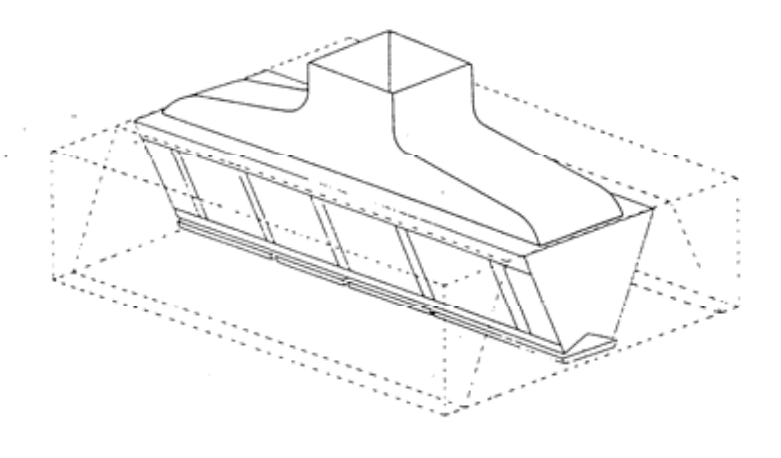

**CANOPY TYPE HOOD**

## **SIDE DRAFT HOODS**

Lateral or side draft hoods shall be provided with an exhaust velocity equivalent to at least 85m/minute measured parallel to and at the face of the filters.

This type of hood is not considered to be as efficient as a canopy type hood where high volumes of deep-frying occur.

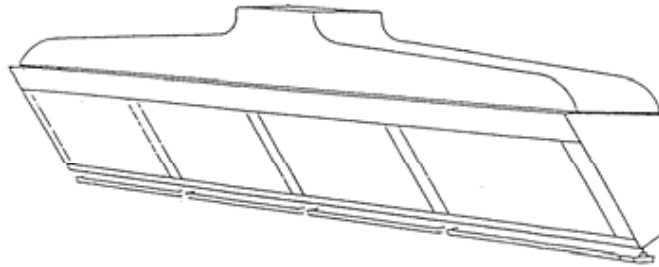

SIDE DRAFT HOOD

## **MAKE UP AIR**

Make up air shall be supplied to the areas where mechanical ventilation is installed by means of an approved induct ventilating system.

Where mechanical induct ventilation is required, it shall be connected electrically with the mechanical exhaust system, and operated by a common switch. Where the make up air is continuously drawn from an external source it shall be free from contamination or impurity. Make up air drawn from an external source may cause discomfort to staff and customers if the ambient temperature of the make up air is higher or lower than the air in the kitchen. In such cases it may be desirable to control the temperature of the makeup air.

## **FILTRATION**

Hoods shall be provided with approved metal washable dry type grease filters in accordance with Appendix E of AS 1668.2 1991.

Filters shall be evenly spaced along the length of the canopy. Filters may be omitted where the hood is exhausting fumes consisting only of heat and/or water vapour.

Filters shall be of an approved non-combustible construction and shall be easily accessible and detachable, by hand without tools, for maintenance and cleaning.

The distance between the lowest edge of the grease filters, and the cooking surface shall be in accordance with Appendix E of AS 1668.2 1991.

## EXHAUST OPENINGS IN HOOD

Connections of exhaust duct work to hoods or canopies shall be located in approved positions in accordance with the following conditions:

- Access is available to all internal sections of the hood for cleaning.
- A uniform capture velocity is maintained within the hood or canopy.
- Right-angled entries to the duct from the hood are not permitted. A tapered transition is required.
- Outlets are evenly spaced in relation to the length of the canopy and in accordance with the following ratios:
- Where the hood length is:
  - less than 3.5 metres (1 outlet);
  - between 3.5 and 7.5 metres (2 outlets).

## HOOD ENCLOSURES

The enclosure of canopy type hoods may be permitted provided that:

- The enclosure and method of fixing is of approved design.
- The enclosure is constructed of smooth impervious fire resistant material.
- Where approved, the material forming the enclosure may be made easily removable for cleaning and maintenance.

## DUCTS

### DUCTS



ROBERTSON TYPE



CYCLO



FIXED 'T' PIECE



CHINAMAN'S HAT



LOBSTER-BACK

Ducts shall be constructed of galvanised sheet iron or other approved noncombustible material in a permanent and tradesman like manner, smooth and free from obstructions on internal surfaces.

Duct joints shall be seamed and grooved or lap riveted and air tight. Alternate methods of jointing having similar mechanical strength and air tightness are permitted.

The girth joints of vertical risers shall be flanged and bolted where required.

Fire dampers shall be installed in ducts where passing through sections of a building other than the room containing the hood or canopy. Fire damper design is to be in accordance with Australian Standard AS 1682 - 1979.

Vertical sections of ducting should only be installed outside the building, however, if it is essential that they be located inside and the building is in excess of one storey in height, it may be necessary for the ducting to be enclosed. In every case, consult the Council's Building Surveyor.

Grease tight inspection openings shall be provided in ducts at intervals of not more than 3 metres and also at every change of direction. These inspection openings shall be large enough to allow easy access to the duct for cleaning purposes. Grease sumps are to be provided at the bottom of every vertical length of duct, other than a section connecting with a hood or canopy.

Horizontal ducts shall be fixed with a minimum fall of 1:100 towards the hood or canopy.

Where the fan motor is located inside the duct, it must be of flameproof construction or be installed within a flameproof enclosure.

Flexible connections in ducts and between ducts and motors shall be provided so as to prevent noise and vibration in the system.

The maximum air velocity through any duct shall be 500m/minute.

Duct work must terminate above the roof at a height and position which will ensure dispersion of exhausted fumes without fouling of any roof or building structure, by providing a vertical upward discharge of fumes, and be fitted with an approved cowl. Cowls will be approved on the basis of being bird proof, weatherproof and allowing ready dispersion of discharged vapours without the creation of a nuisance.

All openings in walls, floors, ceilings or roofs through which the duct passes shall be made proof against the access of rats or mice.

The junction between the roof and the duct is to be made waterproof by means of a collar sealed to the roof. The collar upstand shall be of such dimensions as to leave an annular space between the collar upstand and duct of no less than 10 mm, and be made waterproof by means of a conical shaped weathering collar sealed to the duct.

**Note:** In no case shall be duct be attached to the roof covering (see drawing).

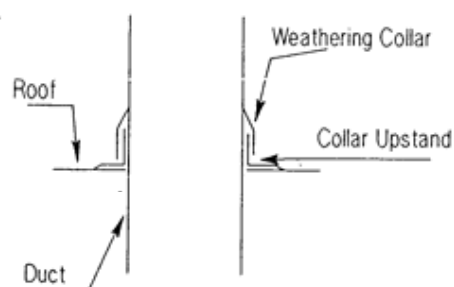

## NOISE EMISSION

Mechanical exhaust systems shall not emit noise nor cause undue vibration which may cause a nuisance.

Mechanical exhaust systems shall be designed to keep noise emissions inside the premises to a minimum. In every case, the A weighted sound pressure level measured midway along the length of the canopy at a point located 0.5 m horizontally from the centre of the filters and 0.5 m vertically down, shall not exceed 70dB(A).

### Notes of Noise Measurements

- The microphone shall be pointed at the centre of the filters.
- A factor of 5dB(A) shall be added for a noise with a tonal component.
- Background sound pressure levels shall be taken at the same location in order to calculate the actual sound pressure level of the mechanical exhaust system.

## SAFETY

The thorough cleaning of filters must be carried out regularly. A second set of clean filters will allow continuation of operations during cleaning.

The cleaning of duct work and ancillary plant with flammable solvents is not permitted.

At least one approved dry chemical type fire extinguisher of 2A40BE rating should be hung in the cooking area conveniently located in relation to cooking appliances.

Fat fryers should be installed a minimum of 400mm away from surface flame cooking equipment.

Salamanders should not be installed above burners, fryers or other cooking equipment which may interfere with its safe operation, or in a position which may impair the efficiency of the canopy.

Cooking fats and oils should not be stored adjacent to or under cooking equipment.

***All mechanical Exhaust Ventilation Systems shall be installed to current engineering and building practices so as not to inhibit the safety of the occupants of any buildings.***

## **FURNITURE AND EQUIPMENT**

Equipment should be installed to be moveable so that the area under, over, behind and between pieces of equipment and walls is easy to clean. If not of the easily removable type, pieces should be sealed to floors, walls or other equipment; or they should be placed far enough away from walls and other equipment to make thorough cleaning possible (min 150 mm).

Every cooking stove or food heating appliance and every refrigerator (other than a cool room or freezer room) in an establishment shall be placed so that it is:

- (a) At least 150 mm from any wall and other equipment;
- (b) On legs of at least 150 mm in height or sealed to the floor on which it stands or on approved castors (which is the preferred option).

Please note that cupboards shall not have false backs, bottoms or cavities. Cupboards are to be sealed to the walls.

## **BENCHES AND SHELVES**

Cavities, false bottoms and similar hollow spaces, capable of providing access and harbourage for vermin are not permitted to be formed in the construction of fixtures and equipment.

Approved type shelving and benches will have a smooth impervious surface free from open joints, cracks and crevices and capable of being easily cleansed. Shelving is to be kept 25 mm clear of the walls and fixed on metal standards or supports with the lowest shelf not less than 250 mm above the floor level.

Plywood, masonite and similar materials are not to be used for 'backing' to shelving in cupboards when fitted against walls.

## **COOL ROOMS AND FREEZERS**

Cool rooms and freezer rooms should be designed and constructed in the following manner:



- (a) Internal lining surfaces of aluminium, stainless steel or colorbond with smooth and impervious finish.
- (b) External wall finishes as for walls generally, pre-fabricated colorbond type insulation panel is acceptable.
- (c) All joints and seams to be sealed.
- (d) Provided with artificial lighting.
- (e) Floor to be impervious, smooth finished and coved internally and externally.
- (f) If the floor is likely to have blood or liquid spilled or where large amounts of water are required for cleaning, the floor shall be graded and drained to the sewer.
- (g) Provided with an efficient thermometer calibrated in the Celsius scale externally.

## TYPICAL FOOD PREPARATION AREA

1. Floor/wall coving
2. Plinth
3. Impervious floor graded and drained
4. Fittings sealed to wall or 150 mm clear
5. Walls tiled to 1800 mm
6. Sealing between fittings
7. Legs 150 mm minimum or approved casters
8. Open design racks
9. Splayed window sill 300 mm above preparation bench
10. Preparation bench - steel framed
11. Bottom shelf 250 mm above floor
12. Mechanical exhaust ventilation canopy
13. Rigid smooth faced ceiling
14. Smooth cement rendering
15. No timber door frames
16. Hand basin, hot and cold water mixing set
17. Soap and towel dispenser
18. Water and drainage pipes concealed in wall

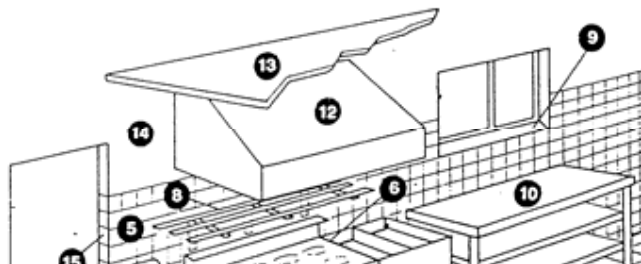

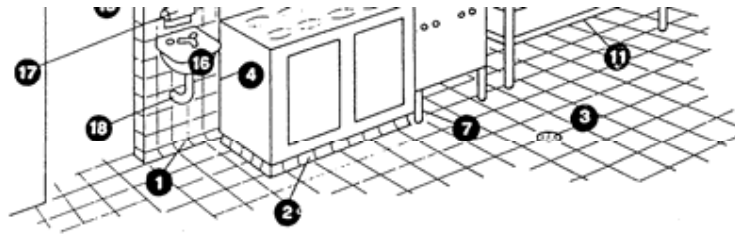

**REQUIREMENTS - Typical Food Preparation Area**

**TYPICAL WASH UP AREA**

1. Floor/wall coving
2. Castors to underbench storage
3. Impervious floor graded and drained
4. Hot water heater sealed to wall
5. Walls tiled to 1800 mm
6. Shelving 25 mm clear of wall
7. Sink unit on metal frame
8. Thermometer
9. Garbage receptacle
10. Dishwasher with temperature indicating device
11. Legs 150 mm minimum
12. Bottom shelf 250 mm above floor
13. Rigid smooth faced ceiling
14. Smooth cement rendering
15. Water and drainage pipes concealed into walls
16. Hand basin, hot and cold water mixing set
17. Soap and towel dispenser

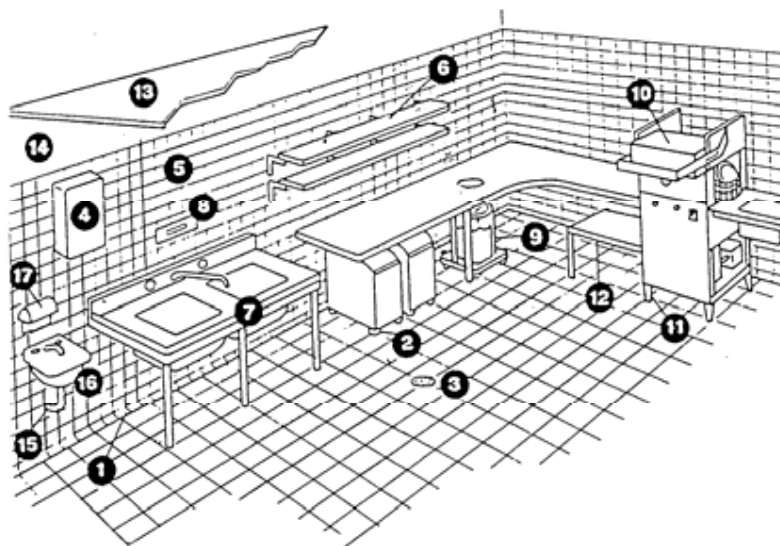

**REQUIREMENTS - Typical Wash-up Area**

## **SINK AREAS & WATER SUPPLY**

Food premises require equipment for cleaning and sanitizing. All sinks need to be connected to a continuous supply of hot and cold water supply of potable water. Sinks should have a water temperature of not less than 45C for washing and 80C for sanitizing. Every food establishment must be provided with a supply of hot water sufficient to provide a continuous pressure flow at a minimum temperature of 70 degrees Celsius during operation. All equipment must be connected to a drainage system. All plumbing service pipes at the premises shall comply with the provisions of the Uniform Plumbing Code and local Sewerage Authority Specifications. Cupboards or enclosures under sinks or basins are not permitted.

Under Food Safety Standard 3.2.2 of Food Standard Code, businesses are required to sanitize eating and drinking utensils and food contact surfaces that are likely to be contaminated by food.

### ***Minimum Requirements –***

#### ***(a) For Washing Up***

1. Premises selling packaged food & drink and/or uncut fruit & vegetables
  - Single bowl sink
2. All other food premises
  - Double bowl sink or trough like sinks
  - Double bowl sink and a dishwasher/glasswasher (where some equip. needs to be washed in sink) *or*
  - Triple bowl sink (where rinsing is required before or after sanitizing)

Where a pair of stainless steel sinks and draining board with hot and cold water is provided, the width and depth of such sinks are to be of sufficient size to enable the largest appliances and utensils to be thoroughly cleansed.

Dish washing areas should be designed to separate “clean” items from “dirty” items.

#### ***(b) For Food Preparation***

1. An additional sink shall be provided **exclusively** for food preparation e.g. washing vegetables, thawing foods etc. All sinks shall be in positions approved by Council

## **WASTE WATER DISPOSAL**

Most food outlets and food services are required to install and maintain an adequately sized boat shaped grease arrestor / grease trap. The size of the grease arrestor / grease trap depends on the volume of greasy wastewater discharged and local authority requirements.

Grease arrestors/grease traps must not be located in areas where food, equipment or packaging materials are handled or stored.

Contact North East Water regarding grease traps in sewered areas.

## **HAND WASH BASINS**

Hand basins should be located preferably at the entrance to where food handling will take place and should be no more than 5m from any place where food handlers are handling open food. Hand basins should also be provided within each toilet facility.

An approved hand wash basin (one to every 30 employees) in the food preparation area is to be provided with an additional wash hand basin as near as practicable to the sanitary convenience. Both fixtures are to have hot and cold running water from a single outlet and the waste pipes connected to an approved Council or Sewerage Authority discharge point. Wash hand basins must not be used for any purpose other than hand washing.

A sufficient supply of soap, nail brushes and single use clean paper towels or other approved hand drying equipment for the use of all food handlers is to be provided. The use of liquid soap dispensers is strongly recommended. A receptacle for used towels must be provided

The wall surface behind hand wash basins and stainless steel sinks shall be faced with ceramic tiles or stainless steel sheeting to a height of 450 mm. Ensure that the wash hand basins and sinks are correctly flashed.

## **STAFF PERSONAL EFFECTS AND CLOTHING**

Change room facilities must be provided where staff routinely change uniforms/clothes on the premises and storage must be provided for personal belongings. This will minimise the possibility of contamination of food by contact with the clothing. When more than four persons of either sex work on the premises, separate changing rooms for each sex shall also be provided.

Where change rooms are not required, clothing and personal belongings can be stored in an enclosed dedicated cupboard located outside the food preparation, processing and storage area.

## TOILET FACILITIES

The Building Code of Australia details the number of toilets required within Food Premises with respect to both staff and patrons. However the Food Safety Standards also requires the provision of adequate toilets for use by food handlers working for the food business. Hands washing facilities are to be provided immediately adjacent to the toilets or toilet cubicles. The hands washing facilities are to include hot and cold water provided through a single outlet, soap and paper towel.

Patrons: The MINIMUM number of toilets required for patrons in a restaurant, café or bar is based on the seating capacity of the premises. Seating capacity is calculated using 1 m<sup>2</sup> of floor space per patron. This calculation is based on the area (m<sup>2</sup>) of the dining area / room regardless of the number of intended seats.

**Please Note:** Disabled access and disabled toilet facilities are required in most situations and in every new building. Please contact the Municipal Building Surveyor for further information about specific requirements.

	Male			Female		Total	
	WC	Urinal	H/Basin	WC	H/Basin	Soil fixtures	H/Basin
No Seating	No public toilets required: staff toilets are required						
Seating 1-10	No public toilets required: staff toilets are required						
Seating 11-20	No public toilets required: staff toilets are required						
<b>Seating 21-50</b> Males 1-25 Females 1-25	1	1	1	2	1	4	2
<b>IF SEATING LESS THAN 50 PATRONS, STAFF MAY USE THE SAME TOILETS AS CUSTOMERS. SEATING 50 OR MORE PATRONS REQUIRES ADDITIONAL (SEPARATE) TOILETS FOR STAFF.</b>							
<b>Seating 51-100</b> Males 26-50 Female 26-50	1	1	1	2	1	4	2
<b>Seating 101-200</b> Males 51-100 Females 51-100	1	2	2	3	2	6	4
<b>Seating 201-300</b> Male 101-150 Female 101-150	2	3	2	4	2	9	4

Staff:

**If seating less than 50 patrons, staff and patrons may share the same facilities.**

	Male			Female		Total	
	WC	Urinal	H/Basin	WC	H/Basin	Soil fixtures	H/Basin
1-10 (working at same time)	Unisex facility may be provided comprising one closet pan, one wash basin and means for the disposal of sanitary towels					1	1
COMBINED STAFF FACILITIES are acceptable where no more than two employees are of the opposite sex							

provided that: -							
• it includes adequate means of sanitary towel disposal							
• facilities have walls, partitions and doors ensuring privacy							
Males 1-20	1	(1-25) 1	1			2	1
				1	1	1	1

**Access to a room containing a closet pan or urinal:**

- (a) Must be by an airlock, hallway or other room with a *floor area* of nor less than 1.1m<sup>2</sup> and fitted with *self-closing* doors at all access doorways; or
- (b) The room containing the closet pan or urinal must be provided with mechanical exhaust ventilation and the doorway to the room adequately screened from view.

**Please speak with Council’s Building department – ph (03) 5755 0555, or your private building surveyor as the number of toilets is controlled by the Building Code of Australia.**

**FOOD STORAGE AND HANDLING**

Ensure that all perishable food is stored at such temperatures as will protect it from spoilage.

Adequate refrigerated space to keep all potentially hazardous foods below 50C is to be made available. Hot foods are to be held at not less than 600C.

All food material, packaged foods, food, drugs and substances therein for sale for human consumption must be protected at all times from flies and other insects, birds, animals, offensive fumes, dirt and as far as practicable, dust.

Food which is consumed in the state in which is it sold (ready to eat foods), should be stored in separate compartments or above raw food which may be a source of contamination.

Separate utensils should be provided for raw foods and for foods usually consumed in the state in which they are sold.

Utensils and equipment should be well protected from contamination, or the effort of cleaning and bactericidal treatment is defeated.

Large utensils such as pots and pans can be suspended from hooks away from splash and spray to conserve storage space.

## SELF SERVE

Unwrapped foods on display must be protected from customer contamination by the use of glass or plastic protective guards. The guards are to be mounted so that they will intercept in a direct line between the mouths of average height customers, and the food being displayed.

Displayed foods are to be provided with heating devices to keep hot foods at 60°C or more, as well as refrigeration devices to keep potentially hazardous foods below 5°C. These temperatures reduce the growth of harmful bacteria.



---

## STORAGE OF REFUSE

Proper storage and disposal of waste in the kitchen is vital in achieving a sanitary and pest-free environment that will reduce contamination.

Appropriate measures need to be taken to dispose of the following:

- Food for disposal
- Grease
- Garbage
- recyclables

Adequate impervious receptacles such as plastic or metal, with properly fitting lids for the temporary storage of refuse shall be provided. Bins that cannot be lifted for draining after cleaning shall have drainage bungs at the base.

A separate room or enclosure or in a yard sited above a paving of impervious material (at least 300mm) and in a manner denying access to flies, insects and rodents shall be provided for the storage of receptacles containing putrescible matter. An approved impervious area properly graded and drained to the sewer or approved drainage system shall be made available for the cleansing of refuse receptacles.

Cleaning materials and equipment are to be stored separately to food storage or preparation areas. A cleaners' trough shall also be installed, preferably fitted with hot and cold water.

All refuse originating from premises shall be temporarily stored in approved receptacles and be disposed of on a regular basis so as to not cause a nuisance.

Large commercial refuse receptacles shall be sanitised after emptying.

Refuse receptacles shall be sanitised on a regular basis.

## **FLY AND VERMIN PROOFING**

The major reasons for pests entering a kitchen are to search for food, water and shelter. It will usually cost more to remove pests than it will to prevent them entering in the first place.

The premises are to be rendered fly proof (as far as practicable) by providing fly wire screens to window and ventilator openings and fitting self-closing doors or an adequate fly repellent air curtain to all doorways. Where fly proofing measures are required on windows, the fly screens shall be of the clip on type, which can be easily removed for cleaning.

Clear overlapping heavy-duty plastic commercially produced door strips will be accepted, as will other approved heavy duty plastic strips. Air curtains, if used, shall cover the whole of the face of the doorway or opening and should have a velocity of no less than 300 metres per minute measured at one metre from the floor.

Roller doors and automatic doors should be so arranged that air curtains come into operation immediately after the door begins to open.

The premises are to be rendered rodent and vermin proof by ensuring that all gaps, cracks, and crevices for services such as gas, electricity and water are sealed in an approved manner.

Insect control devices must not be installed over food preparation areas, exposed food or packaging material. Insect control devices that stun or electrocute insects must be designed to retain the insect within the device.

## **NAME ON FRONT OF FOOD PREMISE**

The proprietor of a food premises shall paint or affix and keep painted or affixed his name in a conspicuous place on the front of such establishment in letters at least 60mm in height and of reasonable proportionate breadth in a colour contrasting with the background on which it is painted or affixed.

## **STRUCTURAL MAINTENANCE AND CLEANLINESS**

Food establishments shall be maintained in good repair and kept in a clean and sanitary condition at all times.



## CHECKLIST

### ITEMS REQUIRED PRIOR TO REGISTRATION OF FOOD PREMISES

- Planning permit (*where required*)
- Notification form submitted
- Application fee paid
- Detailed floor plan (with materials & dimensions marked)
- Plan comment received
- Food Safety Program selected and copy available at premises
- Food Safety Supervisor certified/enrolled in course
- Probe Thermometer available on premises for temperature checks
- Copy of Food Safety Standards and relevant legislation to ensure you understand requirements/standards that you will be expected to meet
- Smokefree dining regulations/stickers (*for those with dining/gaming*)
- Rubbish Disposal/Greasetraps
- Maintenance program for water tanks and septic systems (*where required*)
- Check all suppliers are approved/registered
- Labelling meets FSANZ requirements (*for those manufacturing/producing own products – info available from Council*)
- Inspection of premises by EHO
- Registration form submitted with payment
- Registration certificate received and displayed

Your premises can only be open to the public once you have completed all points of the checklist. It is illegal to operate an unregistered business. Your registration is current until 31 December each year. A renewal will be sent out to you prior to this date. Inspections/audits will be carried out throughout the year to ensure compliance.

## NOTES

1. Employees – a reference to employees includes owners and managers using the building.
2. Urinals – a urinal need not be provided if the number of males employed is less than 10.
3. Unisex facility – instead of separate facilities for each sex, if not more than 10 persons are employed, a unisex facility may be provided.
4. Combined facilities – if the majority of employees are of one sex, not more than 2 employees of the other sex may share toilet facilities if –
  - a) Facilities for females include adequate means for the disposal of sanitary towels; and
  - b) The facilities are separated by means of walls, partitions and doors to afford privacy.
5. Use of public facilities – sanitary facilities for employees need not be separate from those *required* for public use.
6. Sanitary facilities for public – sanitary facilities need not be provided for the public in –
  - a) Building used as a restaurant, café, bar if the building accommodates not more than 20 persons

For females – adequate means of disposal of sanitary towels must be provided.